

**OPERATING AND
MAINTENANCE INSTRUCTIONS**

HC 200



INDEX

1.0 GENERAL COMMENTS	2
1.1 Warnings	2
1.2 Design Standard	2
2.0 TECHNICAL CHARACTERISTICS	3
2.1 General Rules	3
2.2 Standard accessories supplied	3
2.3 Electrical characteristics	3
2.4 Electric connection	3
2.5 Hydraulic Connection	4
2.6 Operation	4
2.7 Programming	5
3.0 MAINTENANCE	7
3.1 General maintenance comments	
3.2 Periodic maintenance	7
3.3 Basic maintenance procedures	7
3.4 Replacing worn parts	8
3.5 Commonly reported problems	9
<u>Chemical Compatibility Table</u>	10
WARRANTY CERTIFICATE	11
Dimensions	12
Connections	13
Parts List	14



**THIS SYMBOL INDICATES SECTIONS
TO READ CAREFULLY!**

1.0 GENERAL COMMENTS

1.1 Warnings

The aim of HC200 pump manual is to provide you with all the necessary information for the correct installation and maintenance in order to give you optimum results whilst in operation.

For this reason it is really important you read giving attention to the instructions given below since they furnish all the indications necessary for the correct installation, use and maintenance



- ◆ This manual has to be preserved with care to be consulted in whatever occasion.
- ◆ At the moment of the receipt you have to check the integrity of the panel and of all its components, in case of anomalies consult skilled staff before making interventions.
- ◆ Before the installation of the pump check that all the data on the pump's label correspond to those of the electrical plant.
- ◆ Do not operate with bare/naked hands or feet
- ◆ Do not leave the equipment exposed to the action of the atmospheric agents.
- ◆ Avoid splashing water
- ◆ The equipment has to be operated by a skilled person.
- ◆ In case of improper functioning of the panel switch off and contact our technical department for any necessary repairs.
- ◆ For the correct functioning it is necessary to use original spare parts and original accessories. The producer refuses any responsibility in reference to break down due to tampering or the use of none original spare parts and accessories.
- ◆ The electrical plant has to be in conformity with the rules of the country where it is operating.
- ◆ The room temperature of utilisation can not exceed 45° C

1.2 Design standard

Our pumps are manufactured according to General Standards in force and in compliance with the following European Directives:

n° 2014/30/CE " E.M.C.

n° 2014/35/CE "DBT Low Voltage Directive"

n° 2011/65/UE , 2012/19/UE "direttive RoHs e WEEE"

However, we think that in order to obtain a high trustworthiness and a lasting functioning pump it is necessary to follow our manual particularly in reference to the maintenance!

The Producer declines all responsibility in reference with whatever works carried out on the equipment from none skilled personnel!

2.0 TECHNICAL CHARACTERISTICS

2.1 General rules

Install the pump:



- ◆ On a horizontal reinforcement (ex: dosing tank) or on the pump shelf (optional) so that the pump head stays always in vertical position +/-15°.
- ◆ Far from a hot source in dry places at maximum temperature of 45°C and minimum 0°C.
- ◆ In a ventilated place and easily accessible by an operator for periodical maintenance.
- ◆ At a suitable height above the chemical up to a maximum height of 1.5 meters. If for exigency of the plant it's necessary to install the pump under the level of the chemical, you need to use an injection valve or an anti siphon valve.
- ◆ Do not install the pump over the tank in presence of liquids that emanate fumes unless it is hermetically closed.

2.2 Standard accessories supplied

- ◆ 1 Foot valve / Strainer.
- ◆ 1 Injection fitting
- ◆ 2 meters opaque PE delivery tubing.
- ◆ 2 meters PVC clear suction tubing.
- ◆ 2 meters PVC clear priming tubing

2.3 Electrical characteristics

Power supply: 230 VAC 50/60 HZ

2.4 Electric connection CAUTION !!!!!



Verify that the earth system is perfectly functional and complies with the applicable regulations. Ensure the unit is connected to a circuit protected by a highly sensitive (0.03A) RCCB circuit breaker. If unsure please consult a competent electrician. Verify that the rated values of the pump are compatible with those of the mains. Never install the pump directly in parallel with inductive loads (e.g. motors/solenoid valves) if necessary, use an isolating relay. There are 2 protection devices inside the pump: a varistor and a fuse.

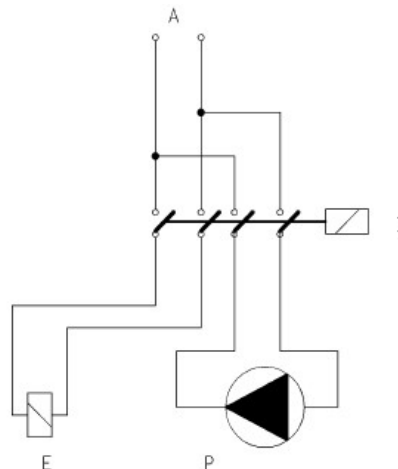
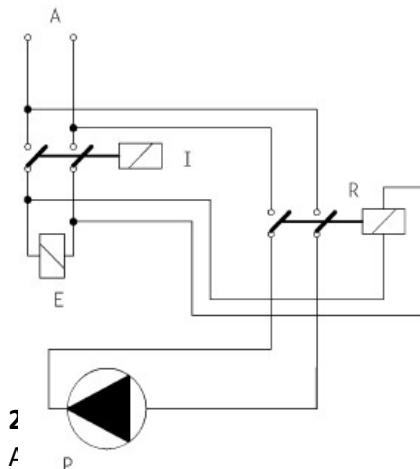

P- Metering Pump
R- Relay
I- Switcher or multi-pole security device
E- Motor or generally inductive charge
A- Supply voltage

Suction: connect the suction tube (PVC soft clear) to the foot filter that is supplied and put it in the hose clamp, lock the tube closing the nut. If it utilises a level probe, this one has to be connected to the filter through the support that is supplied. Put the foot filter into the liquid suction lift tank. Connect the other extremity to the suction of the pump (lower part of the pump head), unscrew the nut from the nipple, take off the plastic white disk situated on the tube connection. Pass the tube through the nut and the adaptor for the 4x6 tube with a simultaneous action of pressing and rotating, put the tube on the nipple conical connection (hose clamp); lock up everything by closing the nuts well.

Delivery: connect the pump to the plant always through the injection valve (1/2" Gm) that is supplied with the installation Kit. Fit a Gf 1/2" threaded connection on your water supply line at the point where you require chemical injection, Use Teflon/PTFE tape on the injection valve and screw into the pipe. Unscrew the nut, put the discharge tube (stiff MDPE) on the hose clamp of the nipple's valve, lock everything by closing the nut fully.

Connect the other end of the tube to the delivery valve of the pump (upper part of the pump head), by repeating the instructions above.

Purge: connect the other hose (2 mt PVC clear) to the hose nipple situated on the pump head bottom right, while the other end is fitted into your chemical drum/ tank.

INSTRUCTION FOR PRIMING

To prime the pump in case of high injection point pressure, turn the purge knob towards you until the pump head is completely full. Screw down again the knob.

ATTENTION!!



If it is necessary to take the pump off the plant, it is important to put the white disk in again, so as to avoid any exit of the liquid contained in the pump head from dripping out. - During the installation ensure that the discharge tubing is fixed correctly so as to avoid any rubbing against hard bodies. Avoid too many bends both on discharge and suction tubing.

- Connect the pump to the plant always through the injection valve (1/2" Gm) supplied with the installation kit.

- Connect the soft PVC tubing only in suction (on the foot filter side), and connect the PE tubing in the delivery side by verifying that the cut of the tubing is clean and that lateral crushing is not caused; it is advisable to utilise a cutter instead of scissors.

2.6 Operation

The metering pump is activated by a Teflon diaphragm mounted on a piston enclosed in an electromagnet, which is fed by continuous current producing a square wave moving the piston thus, a pressure is produced in the pump head with an expulsion of liquid from the discharge valve. Once the electric impulse is off, the return of the piston is spring assisted thus producing the suction action to the initial position, with a recall of liquid through the suction valve. The material used for the construction of the pump makes it particularly suitable for aggressive liquids.

We suggest you always check chemical compatibility tables or our technical department, before use.

**PROGRAMMING INSTRUCTIONS
FOR DOSING PUMP**

HC 200

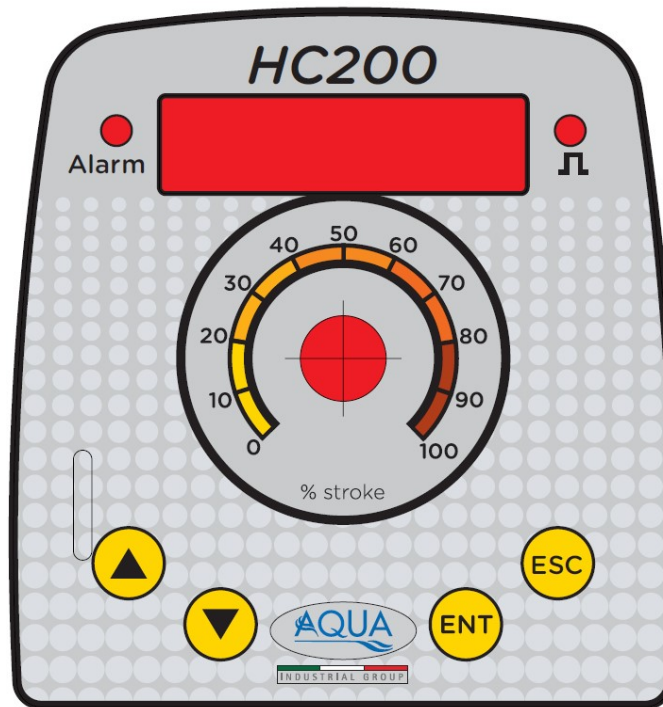

HC 200

This model operates constantly and can only be controlled by the facia mounted on/off switch and the manual stroke frequency control. The frequency is linearly controlled via two Up & Down arrows on the front facia, with the stroking speed per minute (SPM) being displayed. On the front panel there is an ESC key that allows you to activate and stop the pump. Priming is activated by simultaneously pressing the Up and ENT keys.

When the pump is in PASUS a green LED indicates that power is on, the same led pulses in time with the pump stroking speed during the dosing mode. If the HC 200 has the low level option then the RED LED will turn on in the event of low level being reached in the chemical container the dosing pump will stop until the level has been restored.

The HC 200 also has a mechanical stroke length facility in addition to the on/off switch and electronic stroke frequency control function. The operator may now make an extra manual mechanical stroke length adjustment to the dosing pump, thus further increasing the pumps accuracy, and greatly increasing the "turn down ratio" to achieve much lower dosing rates. The stroke length adjustment should only be made when the pump is running, and is achieved by pushing and turning the knob. Failure to push the knob may result in damaging the pump.

NB. Below 10% the adjustment will not be linear.



(THE MECHANICAL STROKE LENGTH SHOULD ONLY BE ADJUSTED WHEN THE PUMP IS RUNNING TO AVOID DAMAGE BEING CAUSED).

PROGRAMMING

The programming of the HC 200 dosing pump is limited to simple frequency speed control via the Up & Down arrows on the front facia. The pump has a button labelled (ESC) which allows you to stop and to start the pump after programming. The ENTER key is not used.

LEVEL SWITCH CONNECTION

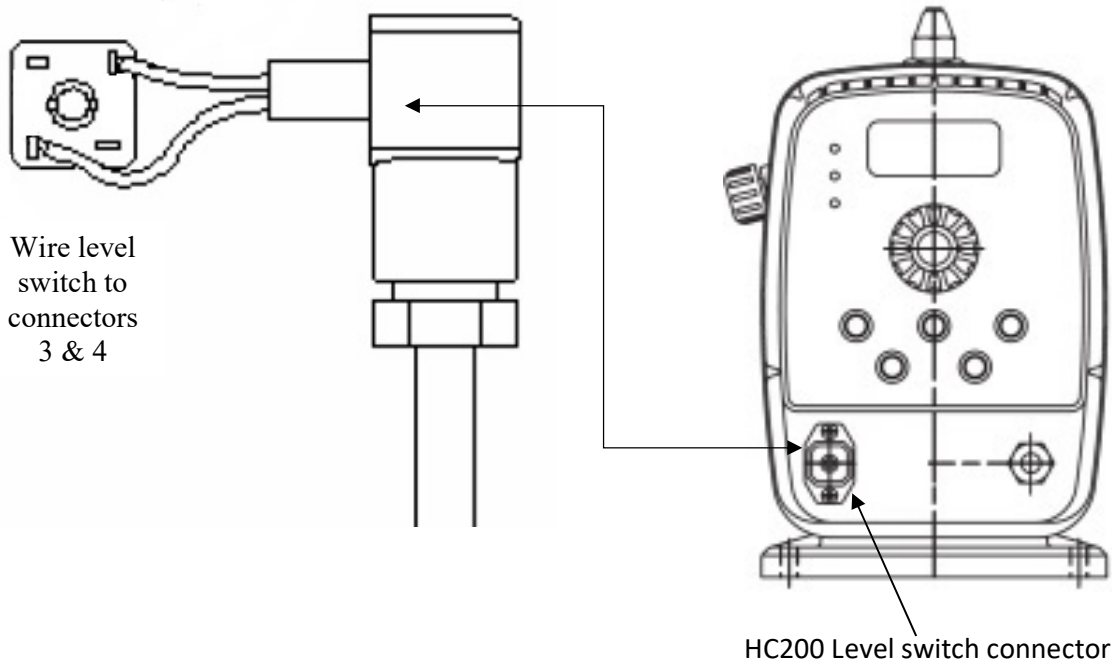

Dimensions

Series HC 200 pump (Fig. 1)

Connection and exploded views

Tubing connections on pump head (Fig. 2)

Manual purge (Fig. 3)

HC200 series Pump Parts diagram (Fig. 4)

Pump head ball and lip valves diagram (Fig. 5)

3.0 MAINTENANCE

3.1 General maintenance comments

Regular maintenance is essential if the pump has to give good service over a long period.

The following advice should be strictly followed:

It is difficult to estimate the periods between maintenance operations, because of the pumps operating conditions and the chemicals employed. It is therefore the basic responsibility of the operator to check regularly the appearance and condition of the pump and to clean and service it according to his findings

3.2 Periodic maintenance



Liquid's level in the tank should be monitored regularly and the tank refilled a necessary to avoid the running dry of the pump. Wet parts of the pump, foot valve, suction/delivery valves and the head and diaphragm should be inspected and cleaned at least every 3 months. Where very aggressive chemicals are being dosed, (Sodium Hypo chlorite is particularly difficult) this period may need to be reduced and cleaning be carried out more frequently. If pumps are not used for long periods, scale, sediment and encrustation deposits can build up causing the pump to malfunction. We highly recommend careful maintenance of the valves by running them under clean water after long periods of non use. Alternatively, if the pump has not been used for long periods, before re-setting up the operations, we strongly recommend operating it for at least 30 minutes with the foot filter immersed in clean water to flush the pump.

3.3 Basic maintenance procedures

Before doing any maintenance read with attention the technical and safety characteristic of the dosing chemicals and follow the next procedures:

1 Turn off the pump and immerse the foot filter and the injection tube in clean water. Turn on the pump to let the water go through the pump head. If there are some crystals to be cleaned follow the next procedures:

2 Immerse the foot filter and the injection tube into an adequate solution to remove the crystals (ex. Chloridric Acid for Sodium Hypochlorite crystals); let the pump work for some minute. Then repeat the action with water and connect the pump to the plant.

ATTENTION!!!!



It's necessary to effectuate all the operations with gloves and glasses suitable for the product used then consult the supplier of the chemical product.

3.4 Replacing worn parts

Fuse replacement.

Proceed as follows:

1. Put at minimum the knob of the piston regulation of the run (in the pump where it is present)
2. Unscrew the fixing screws of the box
3. Open the front and the back part of the box minding the spring of the knob where it is present.
4. Replace the fuse that is well visible.
5. Assemble all the parts paying attention that the piston regulation knob (where it is present) is at the minimum position and that the spring is in .

Valves replacement

NB: Where ball valves are to be replaced, it is recommended that the complete cartridge assembly is replaced, due to the many small parts within.

The procedure is as follows;

1. Using a 19 mm spanner gently remove the cartridge.
2. If a ball valve cartridge is fitted remove the whole assembly and replace with a new one taking care to ensure that the arrow is pointing in the direction of flow, (vertically upwards).
3. If lip valves are fitted, these can be replaced, once again ensuring that they are refitted the correct way up, with their open end downwards, and the lip part in the direction of flow.
4. Refit the nipples and hose clamps to complete.

Diaphragm and O-rings replacement

Proceed as follows:

1. Undo the 4 bolts with an hexagonal key.
2. Remove the pump head.
3. Remove the old O-ring from the head carefully using a small screw driver.
4. By hand, or with pliers if necessary unscrew the diaphragm, and replace with the new one. Hand tight only. Before screwing the diaphragm into place, add a small quantity of Loctite® 222 onto the thread.
5. Refit the dosing head, tightening the head bolts sequentially and carefully to ensure an even airtight seal. Caution do not over tighten. We also recommend adding a few drops of Loctite® 222 on to the thread of the screws that hold the head.

3.5 Commonly reported problems

THE PUMP DOES NOT FUNCTION AND THE GREEN LED IS NOT LIT.

Solutions

1. Check that the electrical connection is correctly made.
2. Check that the fuse has not blown
3. Replace the electronic circuit with a new one.

THE PUMP FUNCTION CORRECTLY BUT NO LIQUID IS INJECTED IN THE PLANT

Solutions

1. Check the product level in the tank.
2. Check the foot filter which could be closed.
3. Check the injection valve is not closed.
4. Effectuate a maintenance of the suction and delivery valves. Parts showing any chemical attack, should be replaced, with alternative materials if necessary.

CHEMICAL LEAKS FROM THE DOSING HEAD.

Solutions

1. Check that the hose clamps are correctly fitted and tightened. Caution do not overtighten these components as they can easily be broken or threads stripped.
2. Check that the head bolts are tight and that the O-ring is in it's correct position. Replace any damaged or worn parts as necessary.
3. Parts showing any chemical attack, should be replaced, with alternative materials if necessary.

Chemical Compatibility Table



Dosing pumps are widely used for dosing chemical products. It is important to select the most suitable material for the liquid to be dosed. The CHEMICAL COMPATIBILITY TABLE is a precious aid to that end.

The following Table must be used as an indicative instrument. Modifications in the transported fluid composition or particular service conditions can reduce the resistance of the materials.

Product	Formula	Ceram.	PVDF	PP	PVC	Hastel.	PTFE	FPM (Viton)	EPDM (Dutral)	NBR	PE
Acetic Acid, Max 75%	CH ₃ COOH	2	1	1	1	1	1	3	1	3	1
Concentrated hydrochloric acid	HCl	1	1	1	1	1	1	1	3	3	1
Hydrofluoric acid 40%	H ₂ F ₂	3	1	1	2	2	1	1	3	3	1
Phosphoric acid, 50%	H ₃ PO ₄	1	1	1	1	1	1	1	1	3	1
Nitric acid, 65%	HNO ₃	1	1	2	3	1	1	1	3	3	2
Sulphuric acid 85%	H ₂ SO ₄	1	1	1	1	1	1	1	3	3	1
Sulphuric acid 98.5%	H ₂ SO ₄	1	1	3	3	1	1	1	3	3	3
Amines	R-NH ₂	1	2	1	3	1	1	3	2	3	1
Sodium bisulphite	NaHSO ₃	1	1	1	1	1	1	1	1	1	1
Sodium carbonate (Soda)	Na ₂ CO ₃	2	1	1	1	1	1	2	1	1	1
Iron chloride	FeCl ₃	1	1	1	1	1	1	1	1	1	1
Calcium hydroxide	Ca(OH) ₂	1	1	1	1	1	1	1	1	1	1
Sodium hydroxide (Caustic soda)	NaOH	2	1	1	1	1	1	2	1	2	1
Calcium hypochlorite	Ca(OH) ₂	1	1	1	1	1	1	1	1	3	1
Sodium hypochlorite, 12.5%	NaOCl + NaCl	1	1	2	1	1	1	1	1	2	2
Potassium permanganate 10%	KMnO ₄	1	1	1	1	1	1	1	1	3	1
Hydrogen peroxide, 30%	H ₂ O ₂	1	1	1	1	1	1	1	2	3	1
Aluminium sulphate	Al ₂ (SO ₄) ₃	1	1	1	1	1	1	1	1	1	1
Copper sulphate	CuSO ₄	1	1	1	1	1	1	1	1	1	1

Component with *excellent resistance* -1-

Component with *fair resistance* -2-

Non-resistant component -3-

Construction materials of pump and accessories

Polyvinylidene fluoride (PVDF) Pump body, valves, fittings, tubes
 Polypropylene (PP) Pump body, valves, fittings

PVC Pump body
 Hastelloy C-276 (Hastelloy) Injection valve spring
 Polytetrafluoroethylene (PTFE) Diaphragm
 Polyethylene (PE) Tubes

Disclaimer



The information included in these tables has been obtained from highly qualified sources which we deem reliable and they are provided without any guarantee, explicit or implicit, concerning their exactness.

Conditions or methods for handling, storage and use of the material are beyond our control and/or knowledge.

For this reason and for other reasons we will not be held liable thereof and we expressly waive obligations of claim for damages or relating to the information contained herein.

WARRANTY CERTIFICATE

The pumps are warranted to be free from defects in workmanship and material for 12 months of operation starting from the delivery date to the first purchaser.

Within the above stated period the producer will supply free of charge any part that upon examination by the producer or by an authorised dealer, is disclosed to have been defective in workmanship or material, or at its option, it will repair the parts directly or through authorised workshops. It remains anyway excluded from whatever responsibility and obligation for others' costs, damages and direct or indirect losses that come from the use or the non-use availability, either total or partial.

The reparation or the supply in substitution will neither extend nor renew the period of guarantee. They remain anyway at charge of the purchaser the costs of plant pumps mounting and disassembling, transport cost and using materials (filters, valves, and so on).

Producer's duties, as above, are not valid when:



- ◆ The pumps are not used according to the producer instructions as in the operating manual and maintenance instructions;
- ◆ The pumps are repaired, disassembled, modified by workshop not authorised;
- ◆ They have used not original spare parts
- ◆ The injection plants are damaged by products that are not suitable;
- ◆ The electric plants have been damaged because of external causes such as whatever type of over tensions.

AT THE END OF THE TWELFTH MONTH FROM THE DELIVERY DATE, THE PRODUCER WILL BE FREE FROM ANY LIABILITY AND FROM ALL THE DUTIES AS ABOVE!

Fig. 1 SERIES "HC 200"

BALL VALVES

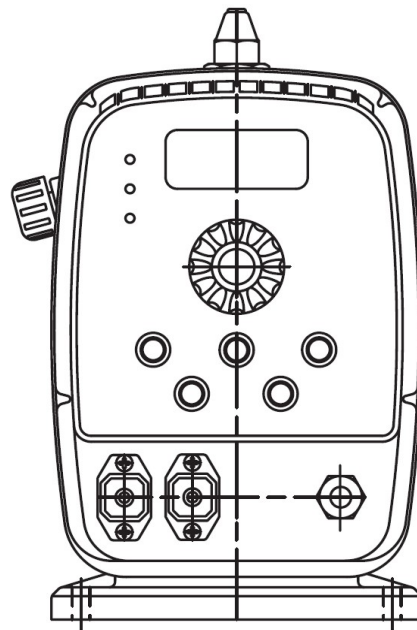
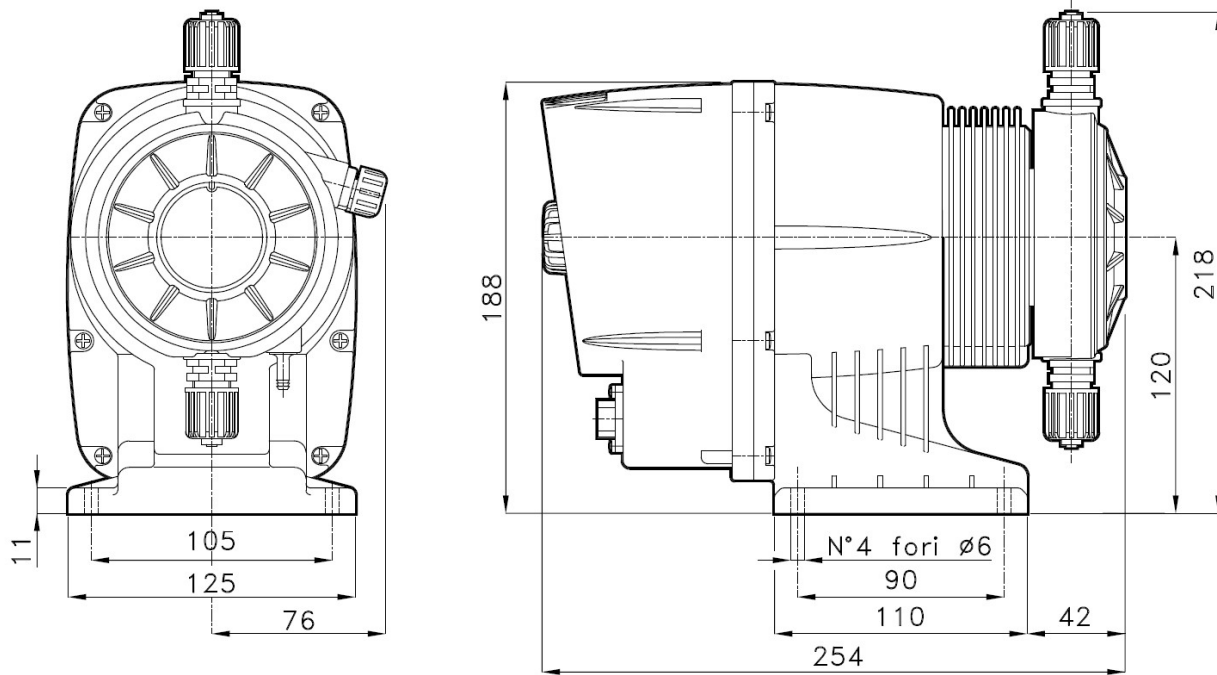

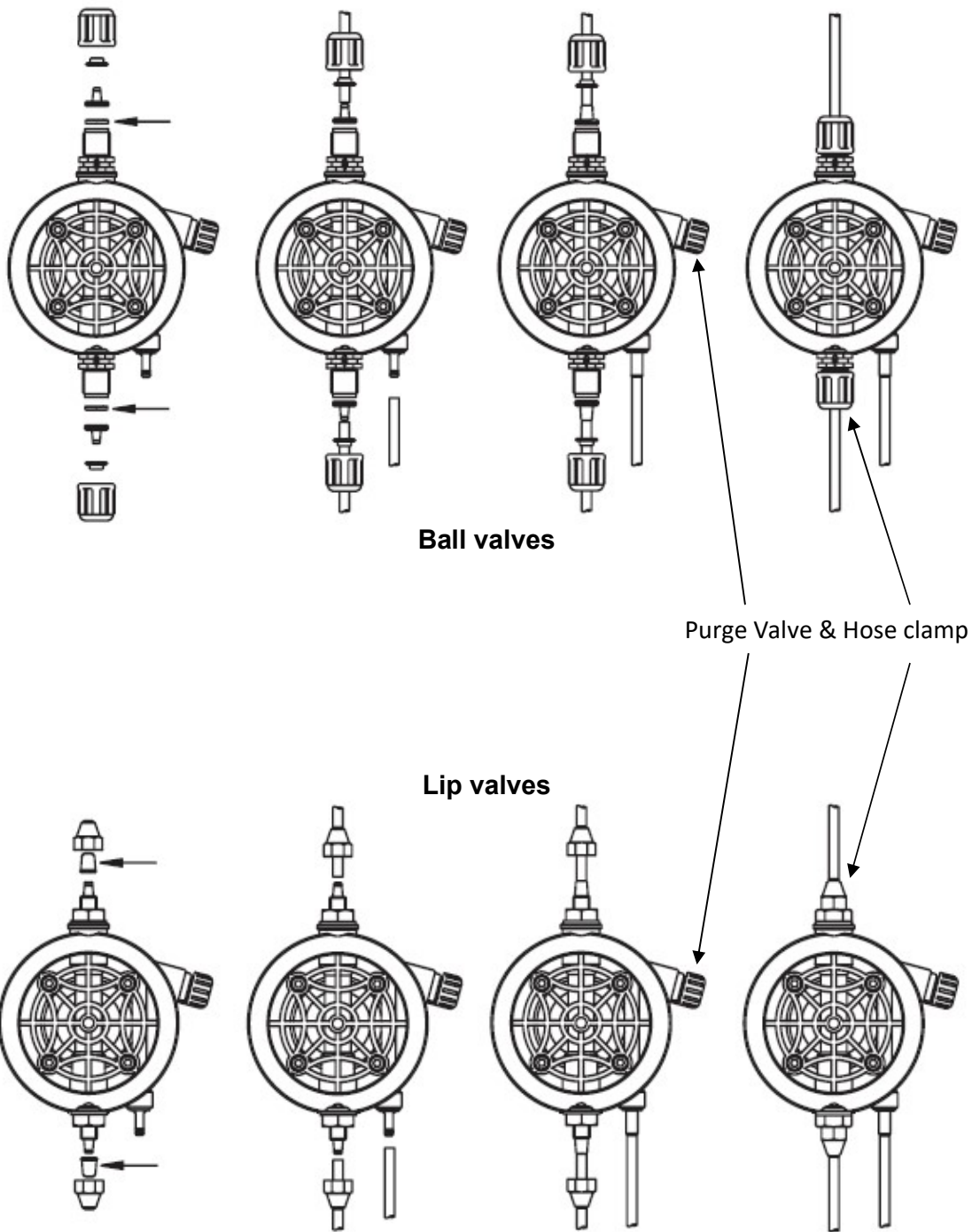

Fig. 2 & 3 PUMP HEAD TUBING CONNECTIONS

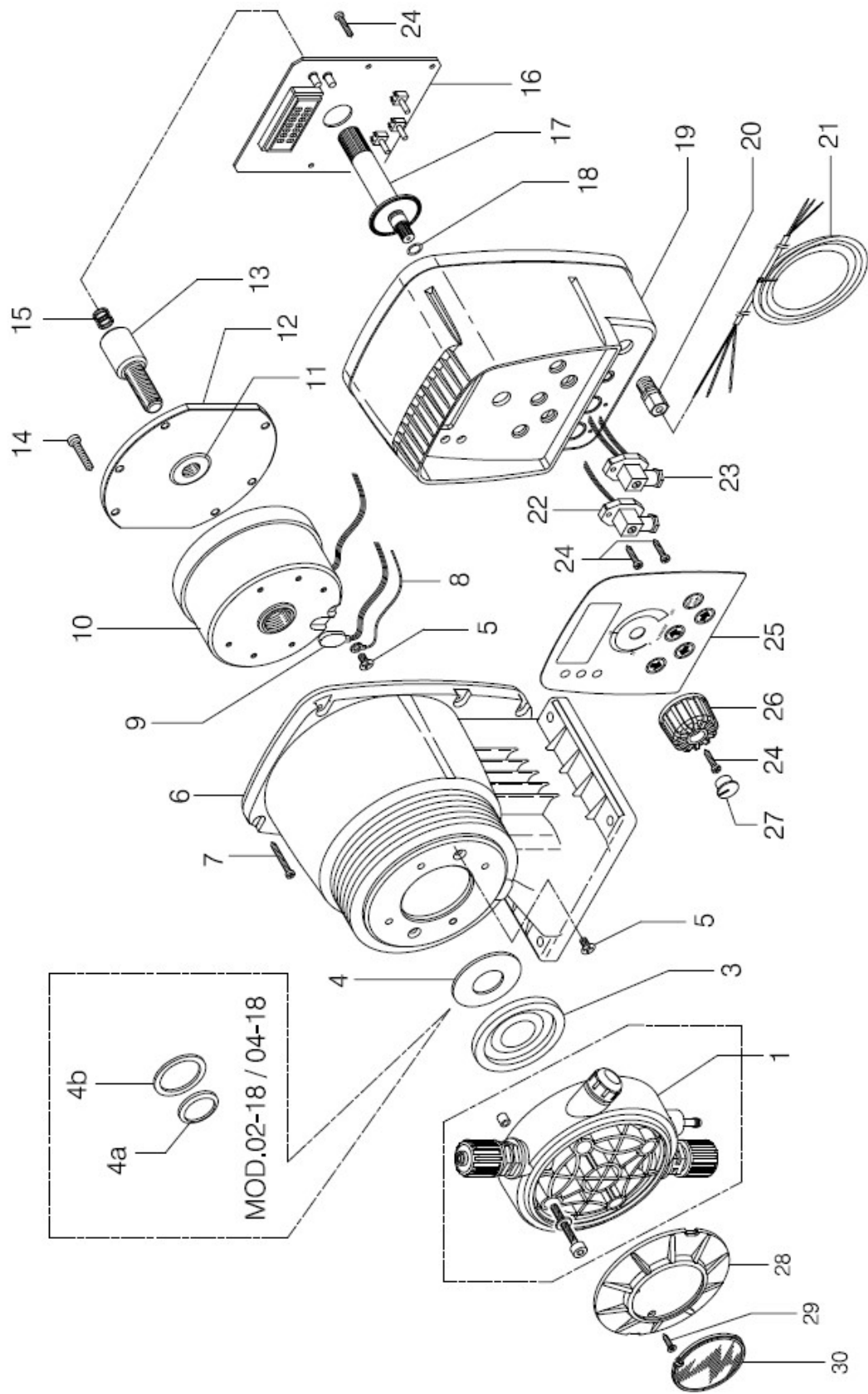
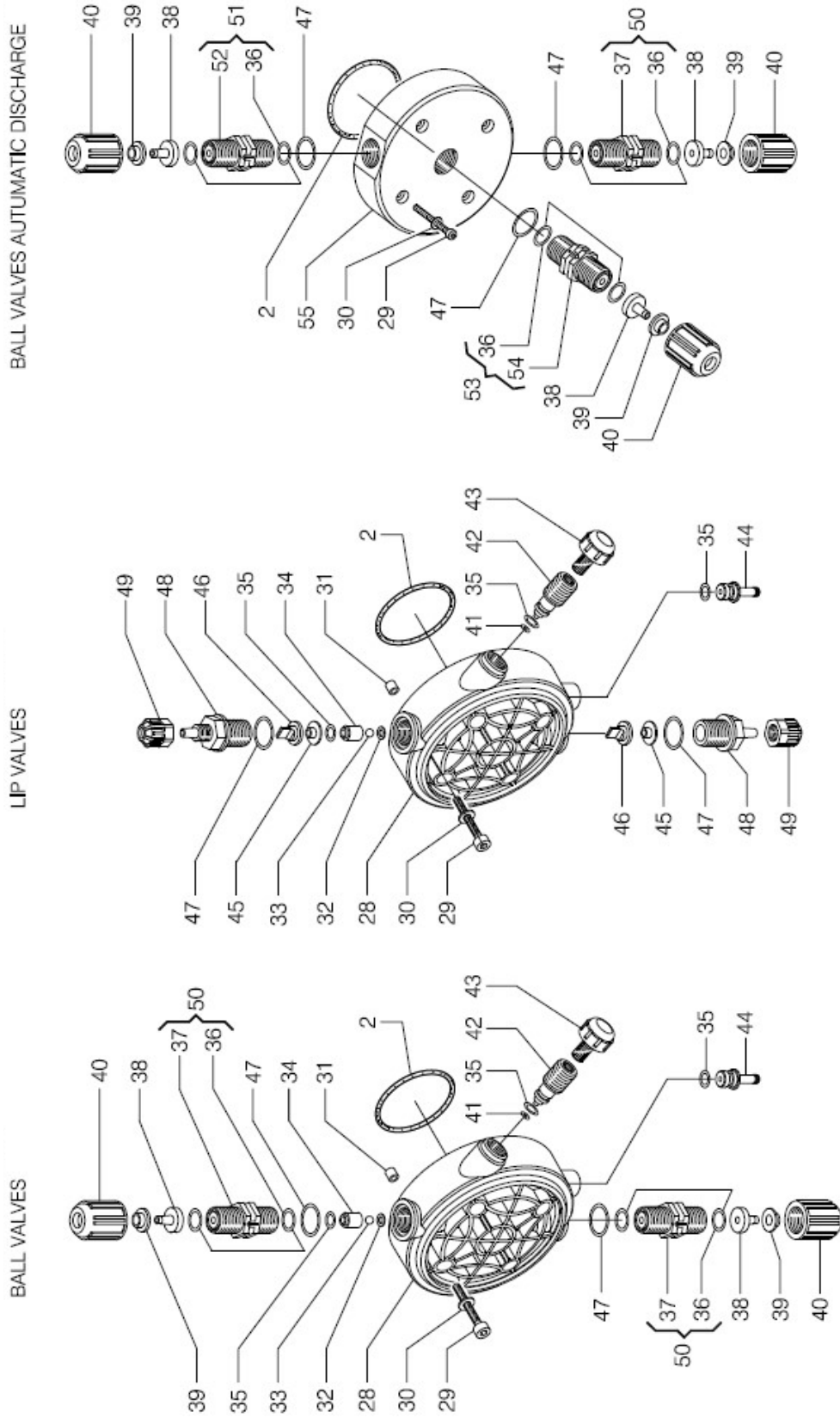

Fig. 4 Pump Diagram

SERIE HC 2

POS	COD	DESCRIZIONE
1	ADSP61000S8A	COMPLETE HEAD 2-15 PP-GL-DT
	ADSP60000S8A	COMPLETE HEAD 2-15 PP-GL-VT
	ADSP6100004	COMPLETE HEAD 2-15 PP-PTFE-DT
	ADSP6000169	COMPLETE HEAD 2-15 PP-PTFE-VT
	ADSP6100008A	COMPLETE HEAD 2-15 PP-VL-DT
	ADSP6000008A	COMPLETE HEAD 2-15 PP-VL-VT
	ADSP6010003	COMPLETE HEAD 2-15 PVC-GL-VT
	ADSP6010005	COMPLETE HEAD 2-15 PVC-VL-VT
	ADSP6100130	COMPLETE HEAD 2-15 PP-SS-DT IN
	ADSP6000092	COMPLETE HEAD 2-15 PVDF-PTFE-DT
	ADSP60000S8P	COMPLETE HEAD 2-15 PVDF-PTFE-VT
	ADSP6100042	COMPLETE HEAD 2-15 PVDF-CE-DT
	ADSP6100041	COMPLETE HEAD 2-15 PVDF-CE-VT
	ADSP6000136	COMPLETE HEAD 2-15 PVC-CE-VT AUTOMATIC DISCHARGE
ADSP6000136P	COMPLETE HEAD 2-15 PVC-PVDF-CE-VT AUTOMATIC DISCHARGE	
3	ADSP6000414	PTFE DIAPHRAGM 4-20BAR
4	ADSP6000420	PISTON FLANGE 5-15L
4a	ADSP6000487	BRASS PISTON FLANGE 20BAR
4b	ADSP6000488	PVC PISTON FLANGE 20BAR
10	ADSP6000277	COMPLETE MAGNET HC2 02-18 230V
	ADSP6000255	COMPLETE MAGNET HC2 04-18 230V
	ADSP6000252	COMPLETE MAGNET HC2 09-09 230V
	ADSP6000257	COMPLETE MAGNET HC2 15-03 230V
	ADSP6000278	COMPLETE MAGNET HC2 02-18 110V
	ADSP6000266	COMPLETE MAGNET HC2 04-18 110V
	ADSP6000267	COMPLETE MAGNET HC2 09-09 110V
ADSP6000268	COMPLETE MAGNET HC2 15-03 110V	
16	ADSP6000358	HC200 CIRCUIT 230V
	ADSP6000355	HC200 P I CIRCUIT 230V
	ADSP6000354	HC200 MA CIRCUIT 230V
	ADSP6000312	HC201 CIRCUIT 110-230V
	ADSP6000334A	HC200 PH/RX CIRCUIT 230V
	ADSP6000380	HC200 CIRCUIT 110V
17	ADSP6000759	STROKE ADJUSTMENT SHAFT
18	ADSP5007035	O-RING 106
24	ADSP6000714	VITE 2,9 X 13 / 2,9 X 13 SCREW
26	ADSP6000507	STROKE ADJUSTMENT KNOB
27	ADSP6000506	STROKE ADJUSTMENT KNOB CAP

Fig. 5 Pump head lip and ball valves /De-Gas



SPARE PARTS

POS	COD	DESCRIZIONE
28	ADSP6000137N	PUMP HEAD 2-15L PP
	ADSP6000137P	PUMP HEAD 2-15L PVDF
	ADSP6000018	PUMP HEAD 1L PP
	ADSP6000022	PUMP HEAD 2-15L 4-20BAR PVC
	ADSP6000021	PUMP HEAD 20L PP
	ADSP6000021P	PUMP HEAD 20L PVDF
	ADSP6000024	PUMP HEAD 30-50L PVC
55	ADSP6000129	PUMP HEAD 2-15L PVC SELF DISCHARGE
2	ADSP5007003	OR 3200 VITON 50,47X2,62 / (FOR 2-15L PUMP HEAD)
	ADSP5007004	OR 3200 DUTRAL 50,47X2,62 / (FOR 2-15L PUMP HEAD)
	ADSP5007099	OR 3200 SILICONE 50,47X2,62 / (FOR 2-15L PUMP HEAD)
	ADSP5009005	OR 3200 PTFE 50,47X2,62 / (FOR 2-15L PUMP HEAD)
	ADSP5007017	OR 3218 VITON 55,25X2,62 / (FOR 20L PUMP HEAD)
	ADSP5007018	OR 3218 DUTRAL 55,25X2,62 / (FOR 20L PUMP HEAD)
	ADSP5007067	OR 3218 PTFE 55,25X2,62 / (FOR 20L PUMP HEAD)
	ADSP5007015	OR 2125 VITON 31,47x1,78 / (FOR 1L PUMP HEAD)
	ADSP5007016	OR 2125 DUTRAL 31,47x1,78 / (FOR 1L PUMP HEAD)
	ADSP5007069	OR 2125 PTFE 31,47X1,78 / (FOR 1L PUMP HEAD)
	ADSP5007019	OR 4312 VITON 78,97X3,53 / (FOR 30-50L PUMP HEAD)
	ADSP5007020	OR 4312 DUTRAL 78,97X3,53 / (FOR 30-50L PUMP HEAD)
29	ADSP6000723	M4 X 35 SCREW A2 TCEI
30	ADSP6000805	D04 X 10 X 1 A2 WASHER
31	ADSP5007011	SPACER D.3,2X6,45X5,5 SANT64A
32	ADSP5007113	ORM VITON D3,00 t2,00 /
	ADSP5007114	ORM DUTRAL D3,00 t2,00 /
33	ADSP5007050	PYREX BALL D.4,76 (3/16")
	ADSP5007051	PTFE BALL D.4,76 (3/16")
	ADSP5007052	AISI 316 BALL D.4,76 (3/16")
	ADSP5107007	CERAMIC BALL D.4,76 (3/16")
34	ADSP6000404	PP BALL CONTAINER FOR AIR DISCHARGE
	ADSP6000403	PVDF BALL CONTAINER FOR AIR DISCHARGE
35	ADSP5007021	OR 106 DUTRAL 6,75 X 1,78 /
	ADSP5007035	OR 106 VITON 6,75 X 1,78 /
	ADSP5007066	OR 106 PTFE /
	ADSP5007102	OR 106 SILICONE /
41	ADSP5007049V	OR 2010 VITON 2,57 X 1,78 /
	ADSP5007055D	OR 2010 DUTRAL 2,57 X 1,78 /
	ADSP5007068	OR 2010 PTFE /
	ADSP5007100	OR 2010 SILICONE 2,57 X 1,78 /
42	ADSP6000786	AIR DISCHARGE SCREW PP
	ADSP6000786P	AIR DISCHARGE SCREW PVDF
43	ADSP6000479	AIR DISCHARGE NUT PP
	ADSP6000479P	AIR DISCHARGE NUT PVDF
44	ADSP6000785	PURGE HOSE PP
	ADSP6000785P	PURGE HOSE PVDF
36	ADSP5007057	OR 2037 VITON 9,25X1,78 /
	ADSP5007056	OR 2037 DUTRAL /
	ADSP5007070	OR 2037 PTFE /
47	ADSP5007001	OR 2062 VITON NERO 15,60X1,78 /

	ADSP5007002 ADSP5008003 ADSP5009004 ADSP5007006 ADSP5007007	OR 2062 DUTRAL 15,60X1,78 / OR 2062 SILICONE 15,60X1,78 / OR 2062 PTFE 15,60X1,78 / OR 2081 VITON NERO 20,35X1,78 / (FOR 30-50L PUMP HEAD) OR 2081 DUTRAL 20,35X1,78 / (FOR 30-50L PUMP HEAD)
50	ADSP5005106 ADSP5005014 ADSP5005025 ADSP5005024 ADSP5005031 ADSP5005027 ADSP5005107 ADSP5005029 ADSP5005028 ADSP5005034 ADSP5005037	BALL VALVE 3/8" PP-GL-VT BALL VALVE 3/8" PP-GL-DT BALL VALVE 3/8" PP-PTFE-VT BALL VALVE 3/8" PP-PTFE-DT BALL VALVE 3/8" PP-CE-VT BALL VALVE 3/8" PP-SS-VT BALL VALVE 3/8" PP-SS-DT BALL VALVE 3/8" PVDF-PTFE-VT BALL VALVE 3/8" PVDF-PTFE-DT BALL VALVE 3/8" PVDF-CE-VT BALL VALVE 3/8" PVDF-CE-DT
53	ADSP5005032 ADSP5005035	BALL VALVE 3/8" PP-CE-HAST-VT BALL VALVE 3/8" PVDF-CE-HAST-VT
51	ADSP5005033 ADSP5005036	BALL VALVE 3/8" FOR AIR DISCHARGE PP-CE-VT BALL VALVE 3/8" AIR DISCHARGE PVDF-CE-VT
38	ADSP6000133 ADSP6000133P	PP BALL VALVE FITTING 4X6 – 3/8' PVDF BALL VALVE FITTING 4X6 – 3/8'
39	ADSP6000132 ADSP6000132P	PP BALL VALVE ADAPTATOR 4X6 – 3/8' PVDF BALL VALVE ADAPTATOR 4X6 – 3/8'
40	ADSP5004005 ADSP5004005P	BALL VALVE 3/8' RING NUT PP BALL VALVE 3/8' RING NUT PVDF
48	ADSP5005001E ADSP5005004 ADSP5005002	LIP VALVE NIPPLE PP NERO 3/8" 4X6 LIP VALVE NIPPLE PVDF 3/8" 4X6 LIP VALVE NIPPLE PP 1/2" 10X14
46	ADSP5001001 ADSP5002001 ADSP5008001 ADSP5001002 ADSP5002002 ADSP5008002	LIP VALVE VITON STANDARD LIP VALVE DUTRAL STANDARD LIP VALVE SILICONE STANDARD LIP VALVE VITON GP LIP VALVE DUTRAL GP LIP VALVE SILICONE GP
45	ADSP5007005 ADSP5007009	LIP VALVE GUIDE STD LIP VALVE GUIDE 20BAR
49	ADSP5004001E ADSP5004002	LIP VALVE RING NUT 1/8' -4x6 PP LIP VALVE RING NUT 1/2' -10X14 PP

Note on environmental protection



After the implementation of the European Directive 2002/96/EU in the national legal system, the following applies:
Electrical and electronic devices may not be disposed of with domestic waste. Consumers are obliged by law to return electrical and electronic devices at the end of their service lives to the public collecting points set up for this purpose. Details to this are defined by the national law of the respective country. This symbol on the product, the instruction manual or the package indicates that the product is subject to these regulations. By recycling, reusing the material or other forms of utilising old devices, you are making an important contribution to protecting our environment.



AQUA WATER SYSTEMS LTD

Unit 135 Oak Drive Hartlebury Trading Estate, Hartlebury
Worcestershire. DY10 4JB
Tel: +44 (0)1299 251050
www.aquaindustrialgroup.co.uk
e-mail: sales@askaqu.co.uk